

TURTLE OILER

It might look small and Insignificant **BUT!**
Without the correct supply of lubricant to your mining tools, pumps etc.
They are all at risk of failure!



TURTLE OILER

Ensure adequate supply of oil to air driven units, pumps etc. with this robust oiler, built for tough conditions.

Easily attached to tools and equipment, whether they be stationary or mobile.

Air direction-flow arrow inbuilt.

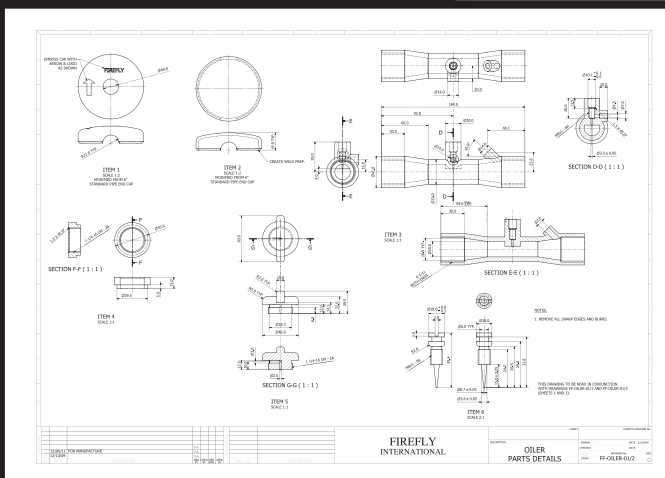
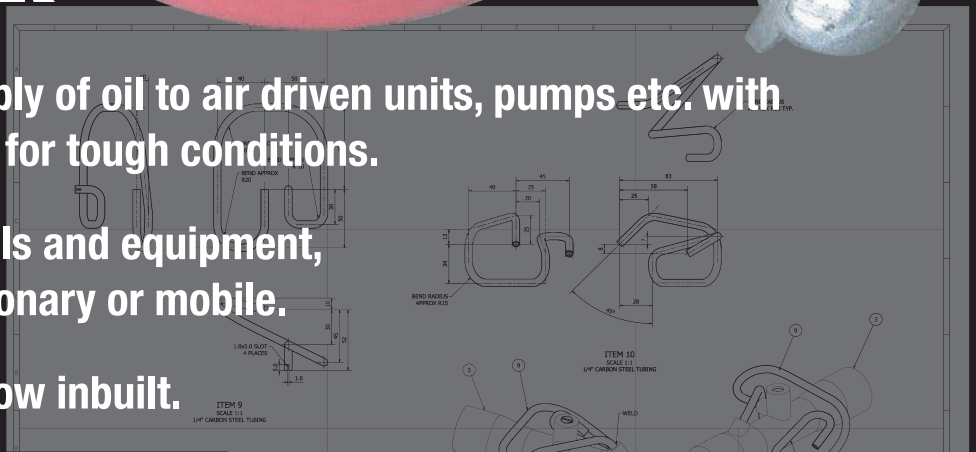

SPECIFICATIONS:-

- Capacity:.....1.5L
- Air Consumption:.....1.5m³ (50-280 cfm)
- Inlet/outlet:.....1" BSP
- Pressure:.....4 - 7 bar

Fittings shown not included,
Firefly will fit connections to suit your requirements